

SIMICS:

Freescale MPC8641D Virtual Platform

Virtutech Simics is a flexible and scalable software solution that models electronic systems with high performance and fidelity. Simics provides the means for corporations to improve their product development lifecycle from bring-up to deployment.

The Simics Freescale MPC8641D Virtual Platform provides a powerful and flexible software development and test platform for systems based on the MPC8641D SoC. With Simics, resolving multicore-related software issues is much easier with key features such as deterministic execution, the ability to save execution state and continue executing from that point at a later time, and the ability to inspect and control the state of any device (even those within the SoC itself). Once a bug has manifested itself, reverse execution allows one to quickly pinpoint the actual source of the bug. Simics can be used in conjunction with most software development environments and source level debuggers.

The Simics Freescale MPC8548 Virtual Platform allows teams to decouple their hardware and software development, and reduce overall product development risk. In addition, Simics allows every member of the software, test, and integration teams to have a virtual platform on their desktops greatly reducing the bottlenecks associated with sharing a limited number of hardware targets.

The Simics MPC8641D Virtual Platform is flexible. Using Virtutech's DML (Device Modeling Language), this virtual platform can be modified, extended and configured to match your production version target hardware, including any custom ASICs or FPGAs. Devices can be attached to high-speed interfaces like RapidIO and PCI Express, or to the local bus and I2C bus. Virtutech provides a large library of common standard components that accelerates the construction of your custom system.

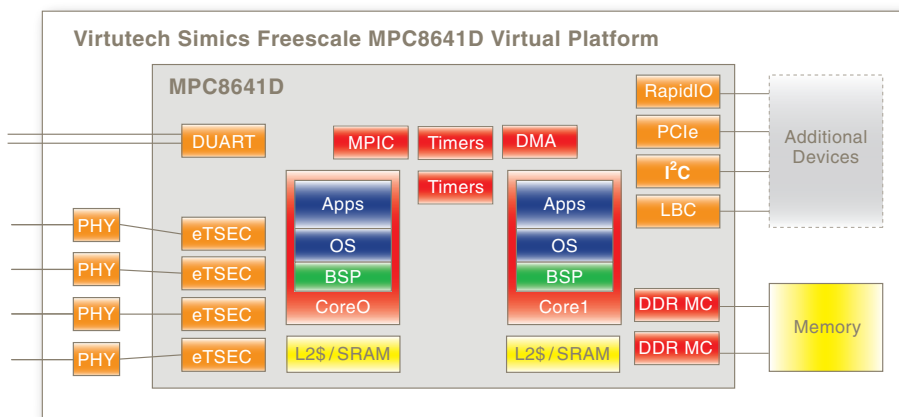

The Simics Freescale MPC8641D Virtual Platform can be networked with other instances of the same system, or with virtual systems based on other Freescale processors or processors from other vendors. Simics has been proven to handle systems consisting of hundreds of processors and tens of distinct networks.

Simics MPC8641D

At-a-glance

- > Virtual platform on every developer's desktop
- > Deterministic execution
- > Runs unchanged binaries including drivers, BSP, RTOS, etc
- > User-extensible to model custom systems
- > Provides a superior debug platform
- > Reduces time to market

Key Uses

- > Debug hard-to-find multi-core software issues
- > Develop and test software independently of hardware availability
- > Quickly debug complex multicore problems in a deterministic environment
- > Set up and debug complex virtual networks
- > Debug & test drivers for on-chip SoC devices and custom boards
- > Scriptable hardware fault injection to stress-test the software

MPC8641D Virtual Platform Features

- > Single or dual e600 processor cores
- > Symmetric or asymmetric multiprocessing
- > Coherency controller
- > eTSEC Ethernet controllers
- > Dual DDR memory controllers
- > DMA controller
- > Timers
- > RapidIO
- > PCI Express
- > Local Bus
- > I2C



Usage Configurations for the Virtutech Simics MPC8641D Virtual Platform

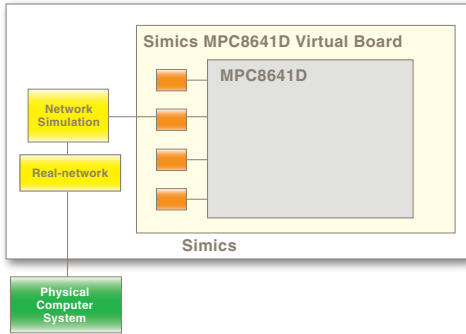

The MPC8641D Virtual Platform can be interfaced to the real-world network containing physical computers.

This lets you use existing network test equipment and network-connected development tools with the Virtual Platform.

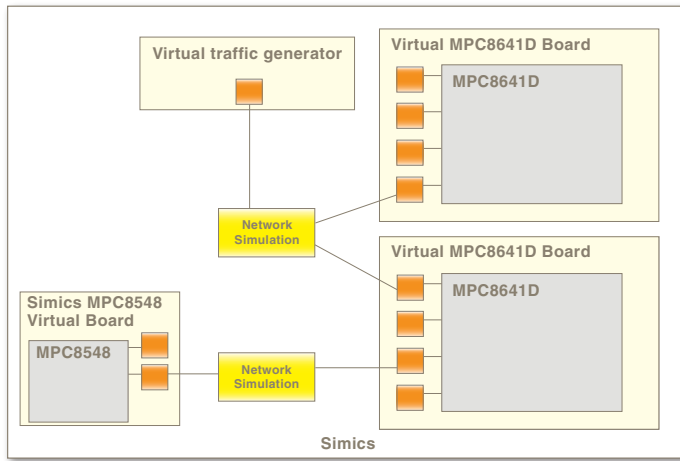

The Simics MPC8641D Virtual Platform can be customized by the user to model the characteristics of their own MPC8641D-based board.

This MPC8641D virtual board can be used in a virtual network configuration with multiple boards of different types and a network traffic generator.

This is a common configuration when building systems containing multiple boards, connected over Ethernet networks.

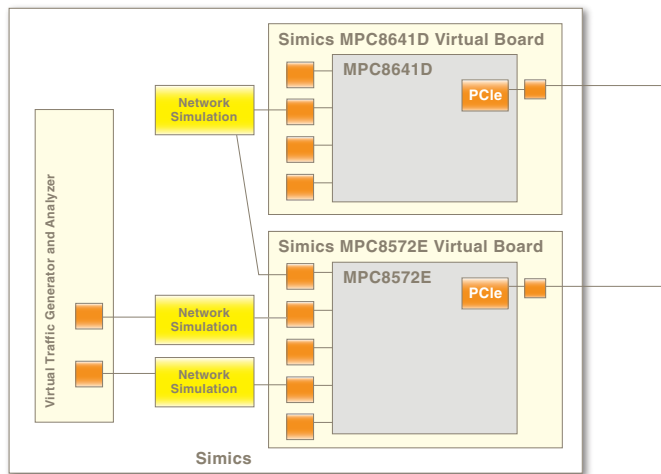

The MPC8641D virtual board can also be setup in a rack-based configurations where several boards are connected using a PCI Express, RapidIO, or Ethernet backplane. Typical examples are ATCA systems or custom blades.

In this particular case, we combine an MPC8641D-based control-plane card with an MPC8572E-based line card. We also have an intelligent network tester to drive traffic through the line card.

For more information, please read our Simics for Virtualized Software Development datasheet located at http://www.virtutech.com/pdf/simics_datasheet_v3.2.pdf



Contact Us:

www.virtutech.com

North America

sales_americas@virtutech.com

Phone: +1 408-392-9150

Japan

sales_apac@virtutech.com

Phone: +81 3-6717-6051

Asia Pacific

sales_apac@virtutech.com

Phone: +65 9780-1295

Europe, Middle East, and Africa

sales_emea@virtutech.com

Phone: +46 8-690-0720